

# Kontax Stirling Engines KS160 instructions

This document covers the following:

- [Tools required](#)
- [Parts list](#)
- [Assembly instructions](#)
- [Operating instructions](#)

Contact details:

- [www.stirlingengine.co.uk](http://www.stirlingengine.co.uk)
- [Kontax@btconnect.com](mailto:Kontax@btconnect.com)
- Tel: 01628 773212 (UK)

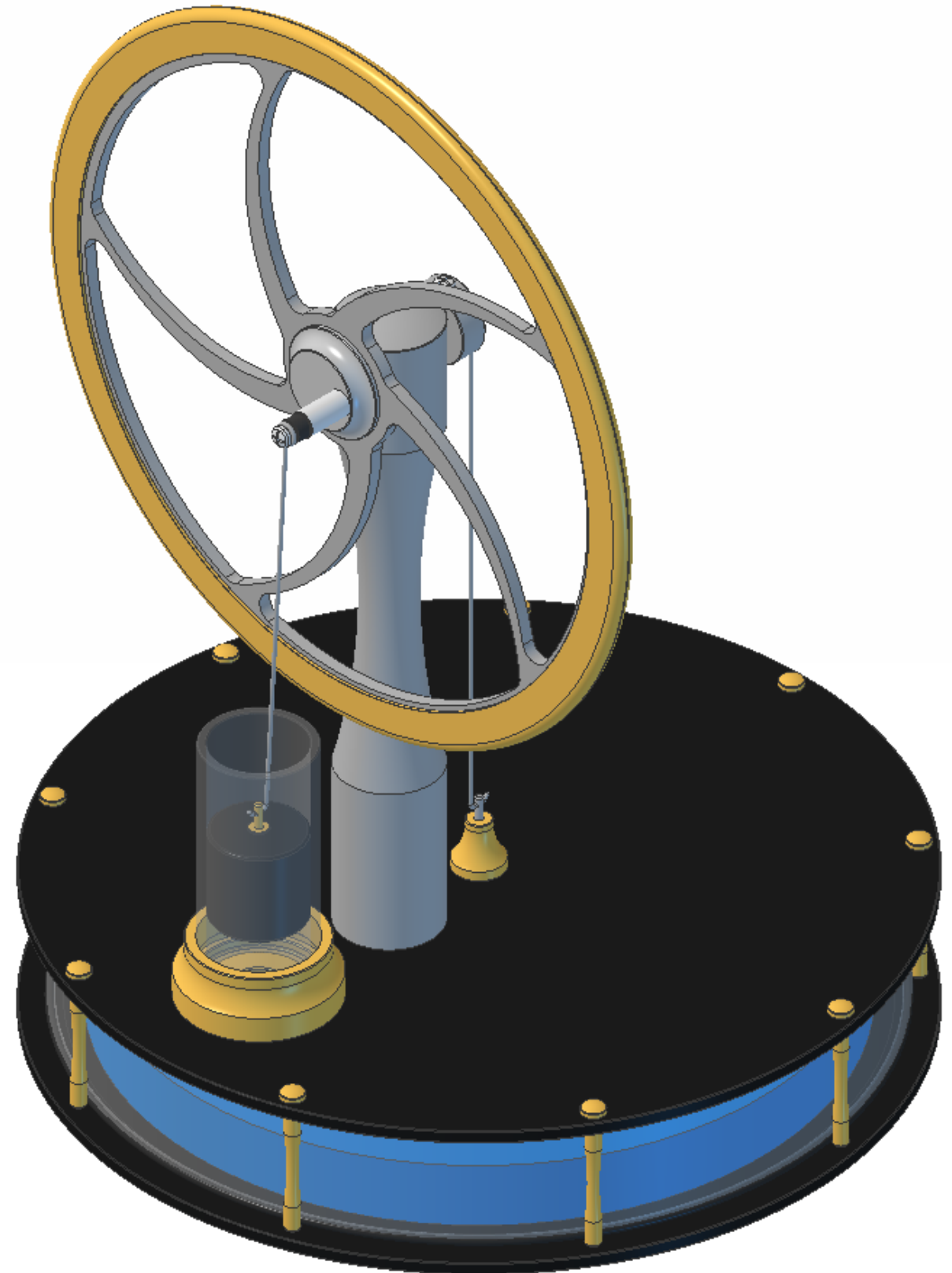

Tools you will need to assemble your  
KS160 Stirling Engine:

Cross-point screwdriver.

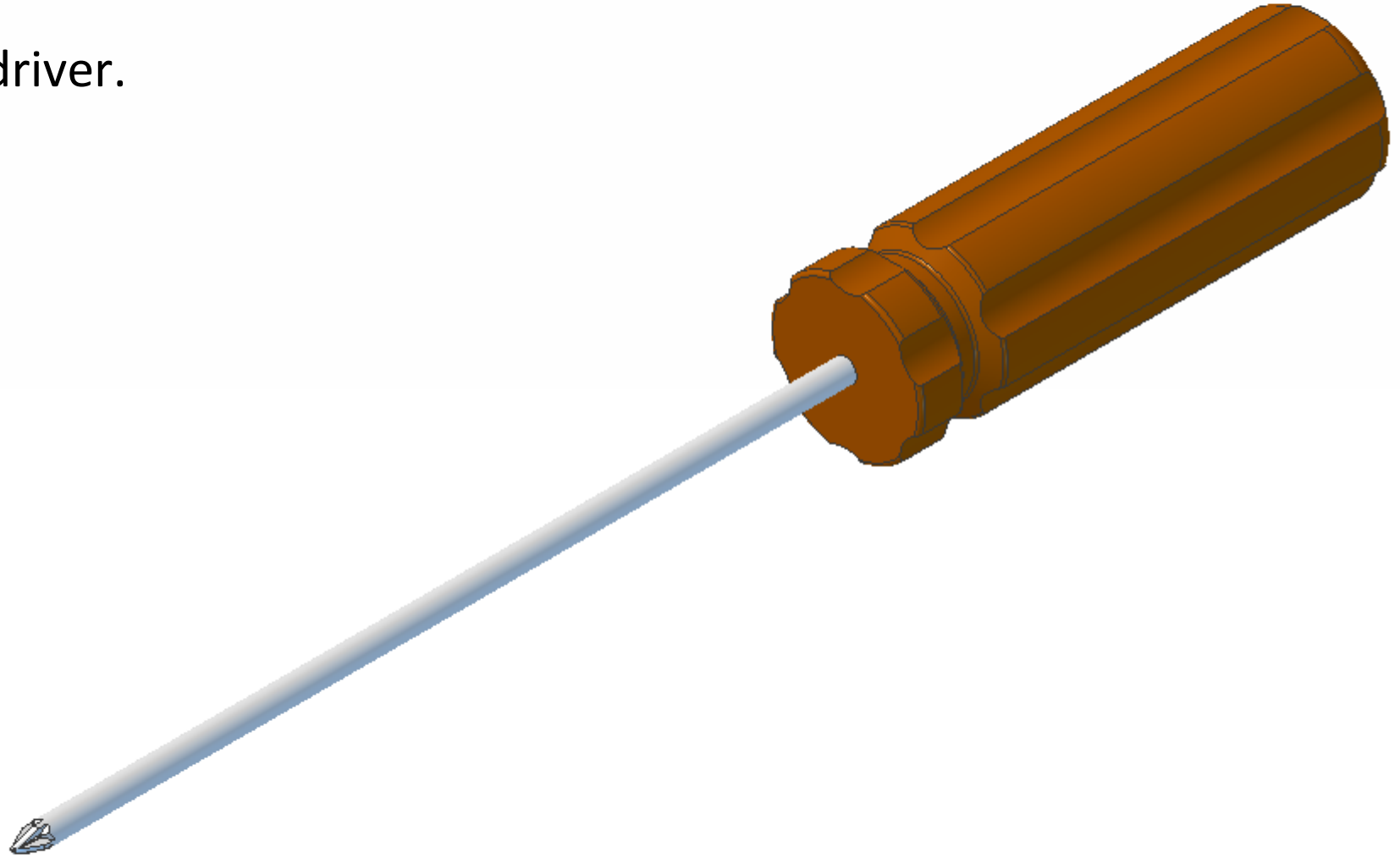

Base section

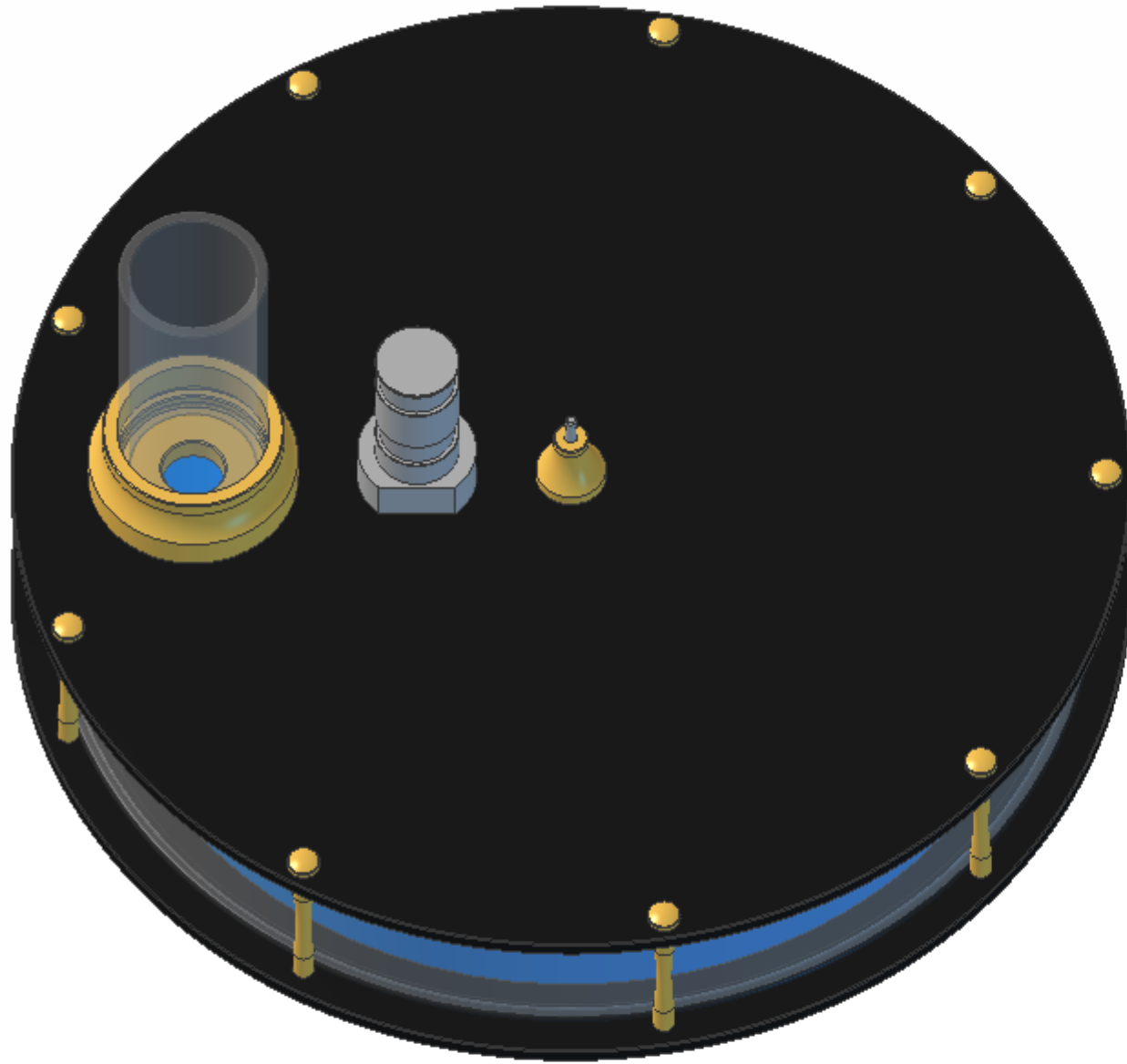

Piston conrod and piston

Top section

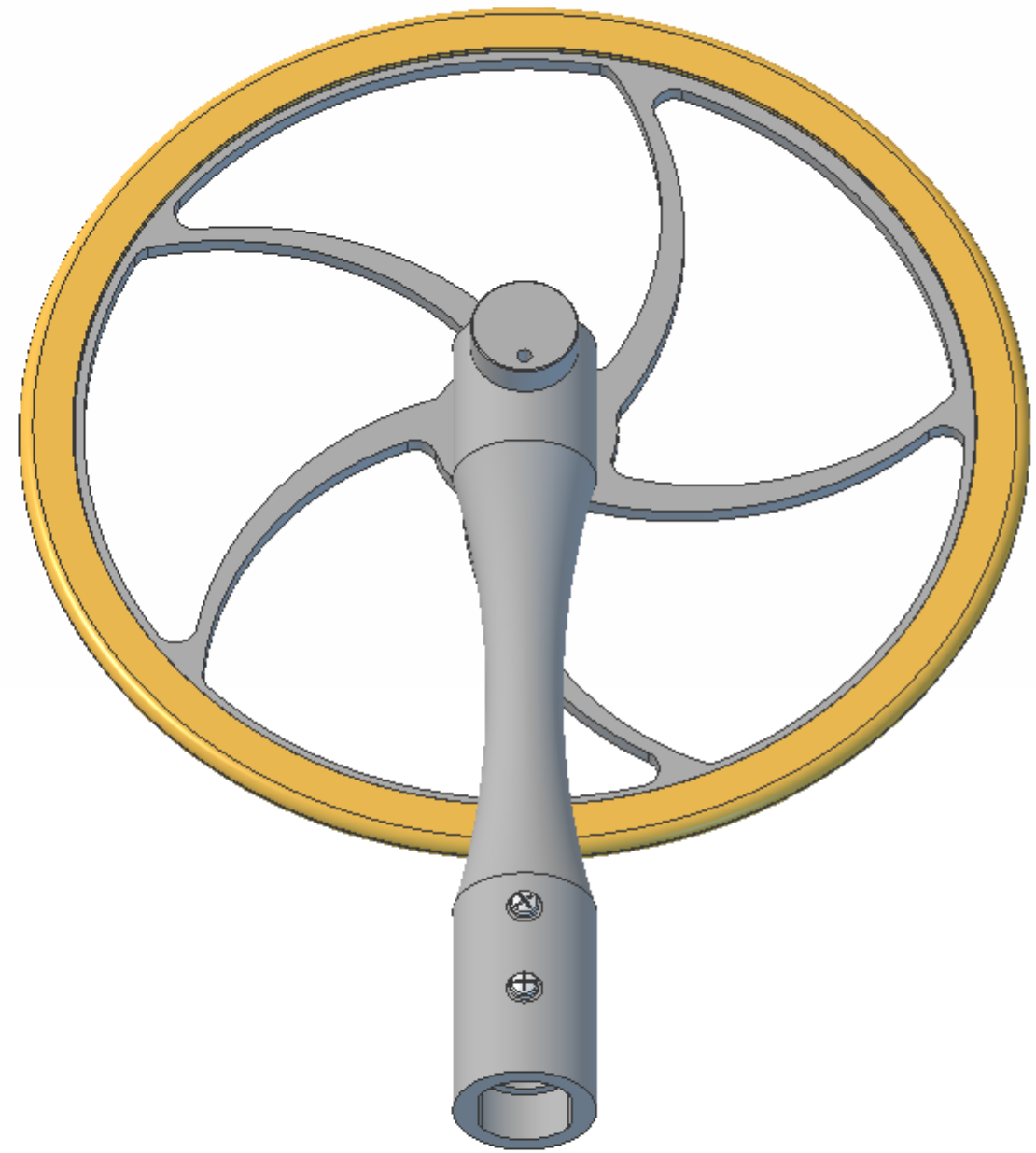

Displacer conrod

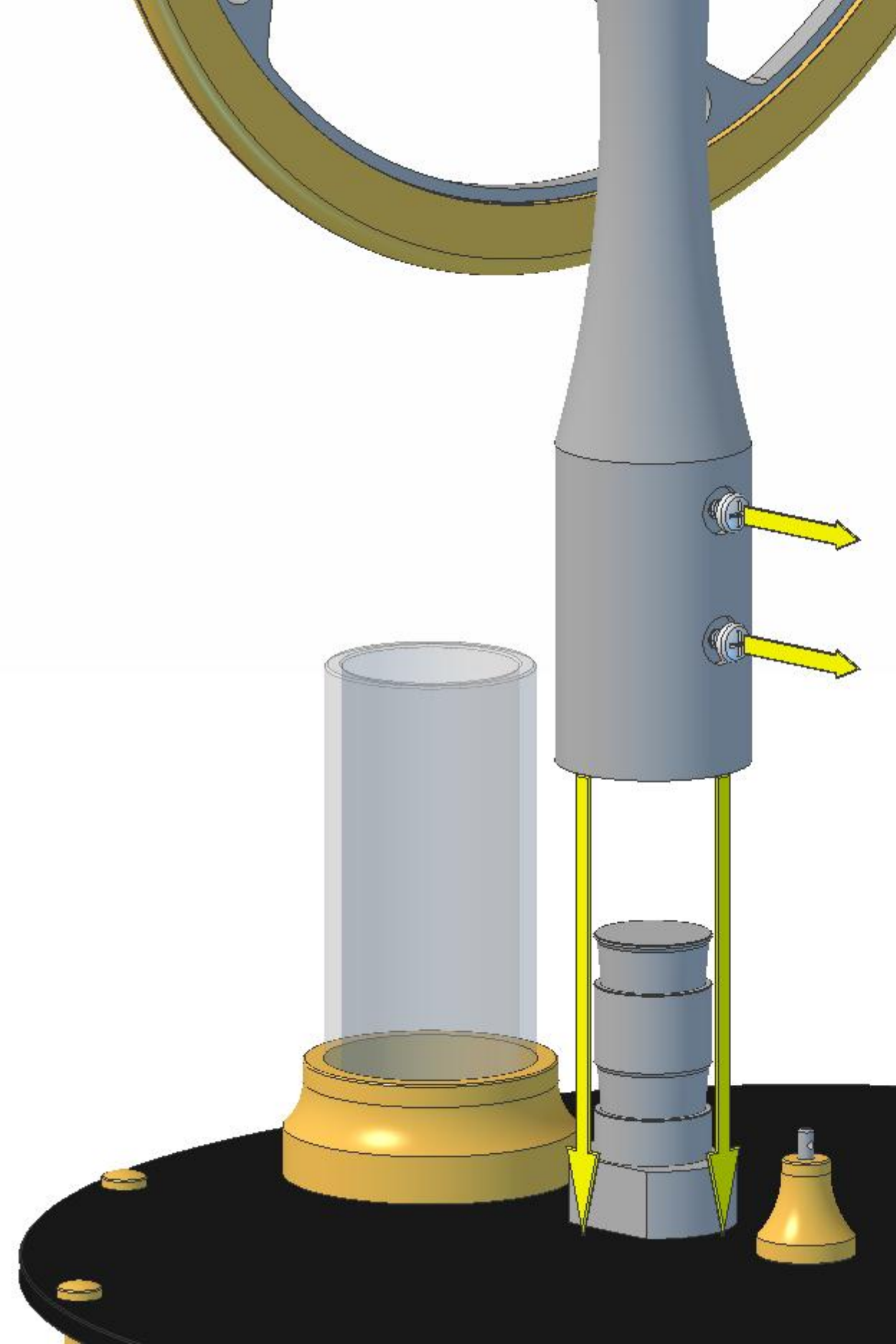

Fit the main pillar over the stub pillar on the base section. Align the two locking screws as shown in the diagram.

The main pillar should fit right down over the stub pillar and sit flush on the top of the top plate.

Keep the main pillar firmly pressed down on the top plate and fully tighten the two screws. You will need to angle the screwdriver slightly to the side when tightening the bottom screw.

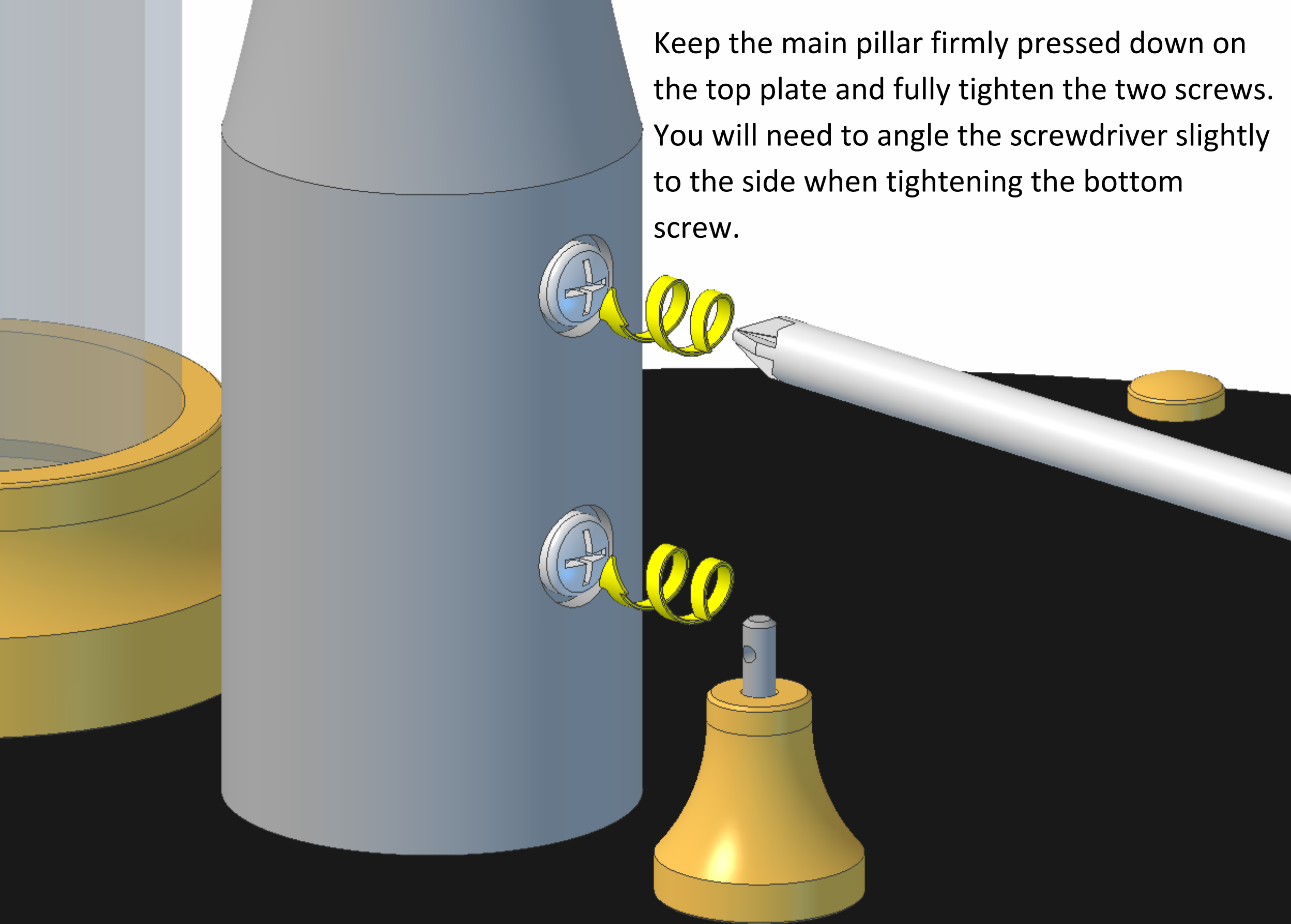

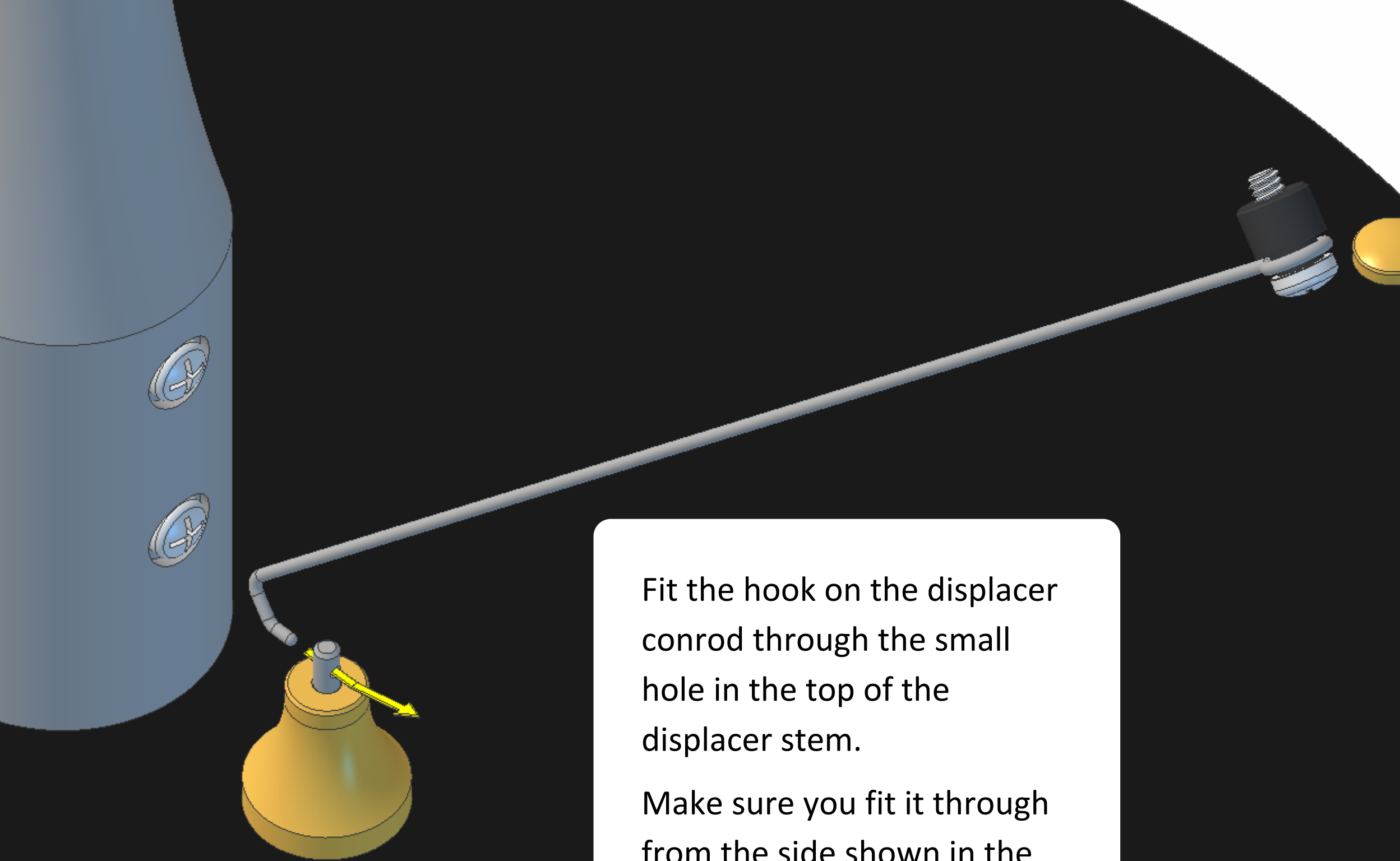

Fit the hook on the displacer  
conrod through the small  
hole in the top of the  
displacer stem.

Make sure you fit it through  
from the side shown in the  
diagram.

Screw the conrod screw into the hole in the front face of the crank. Tighten only sufficient to lock, over-tightening will cause the conrod bush to expand and pinch the conrod eye, which could prevent your engine from running.

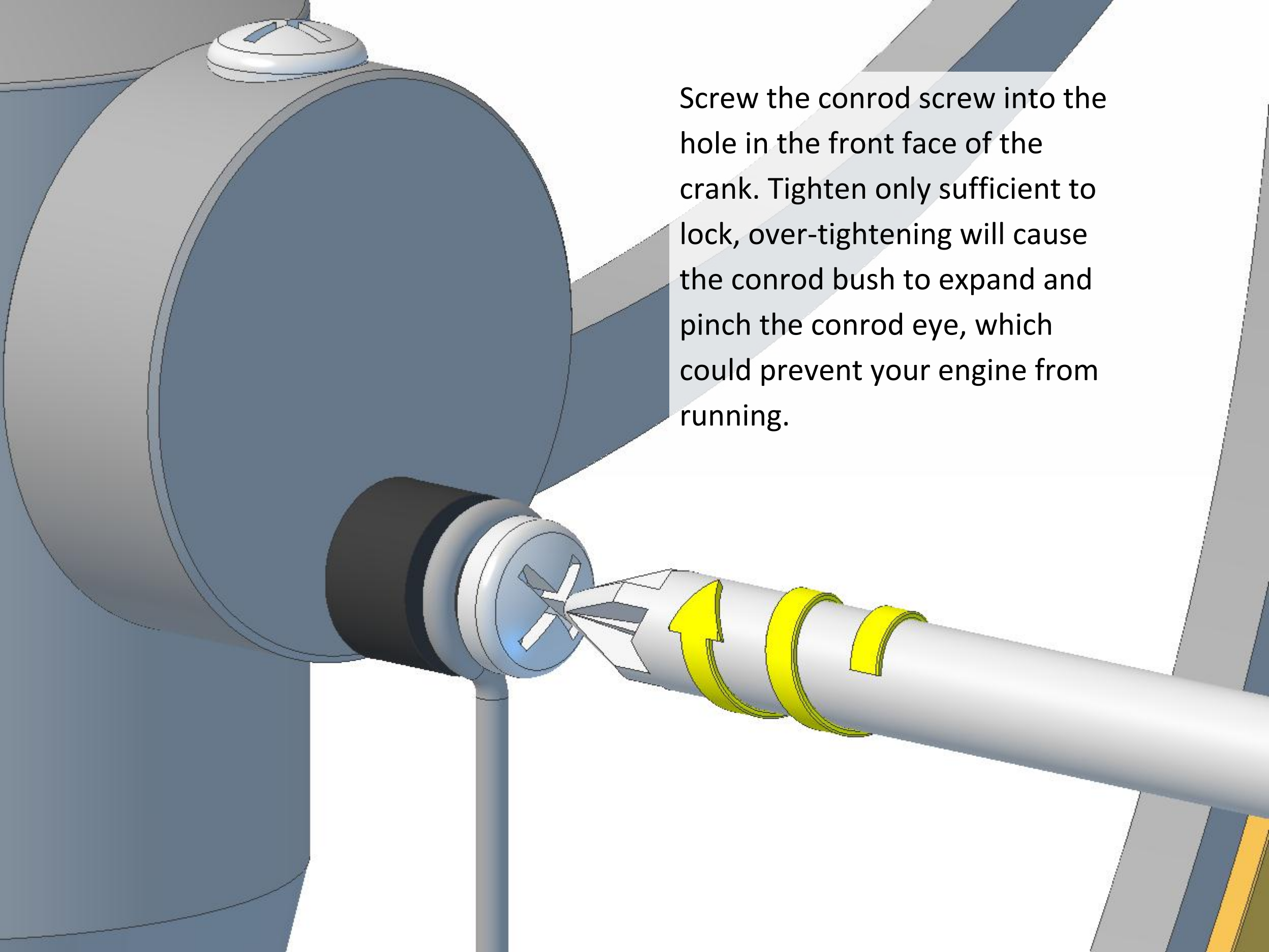

Slide the piston and  
conrod into the cylinder.  
Some air pressure should  
be felt as you slide it in.

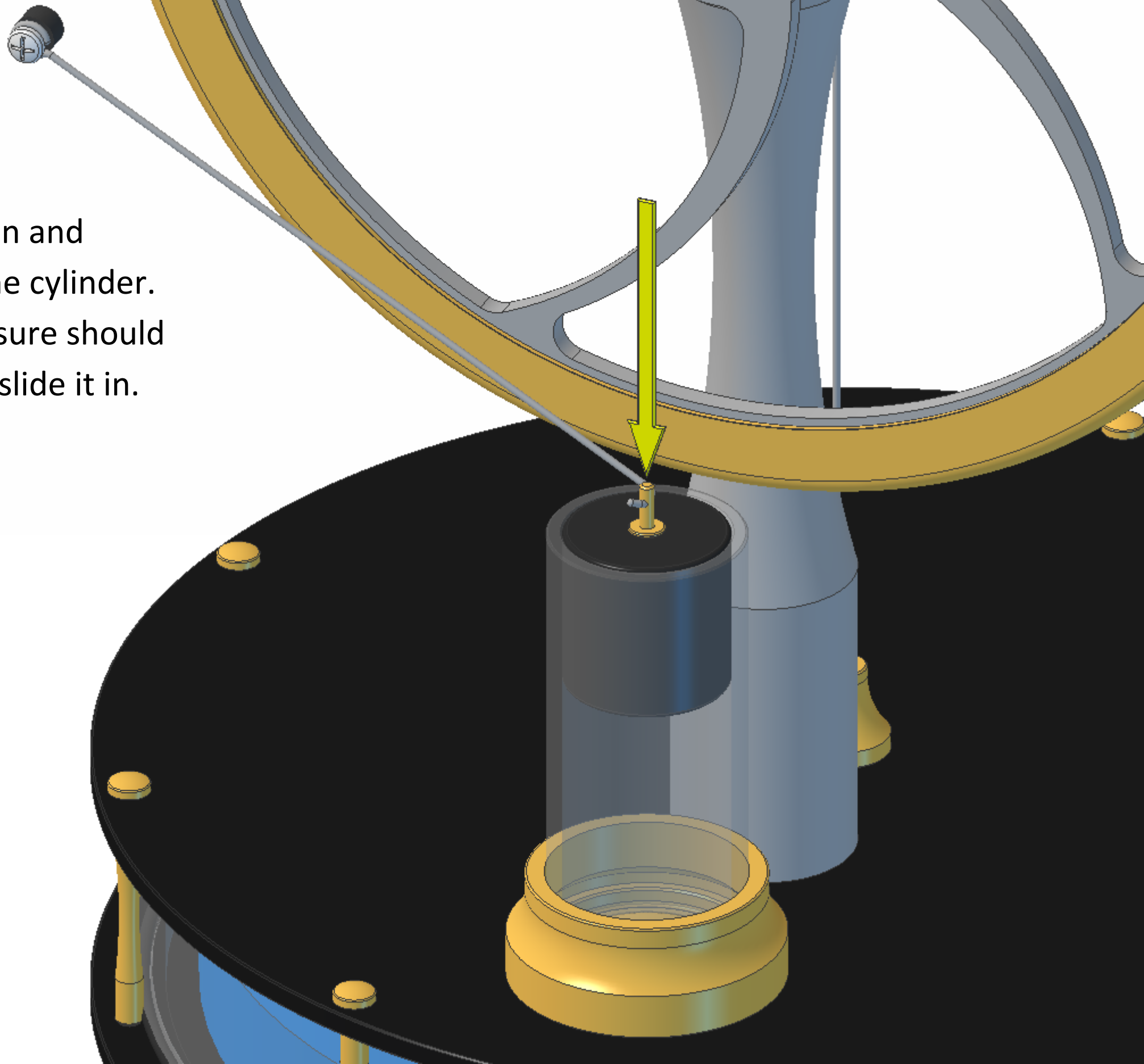

Screw the conrod screw into the hole in the end of the hub extension.

Tighten only sufficient to lock, over-tightening will cause the conrod bush to expand and pinch the conrod eye, which could prevent your engine from running.

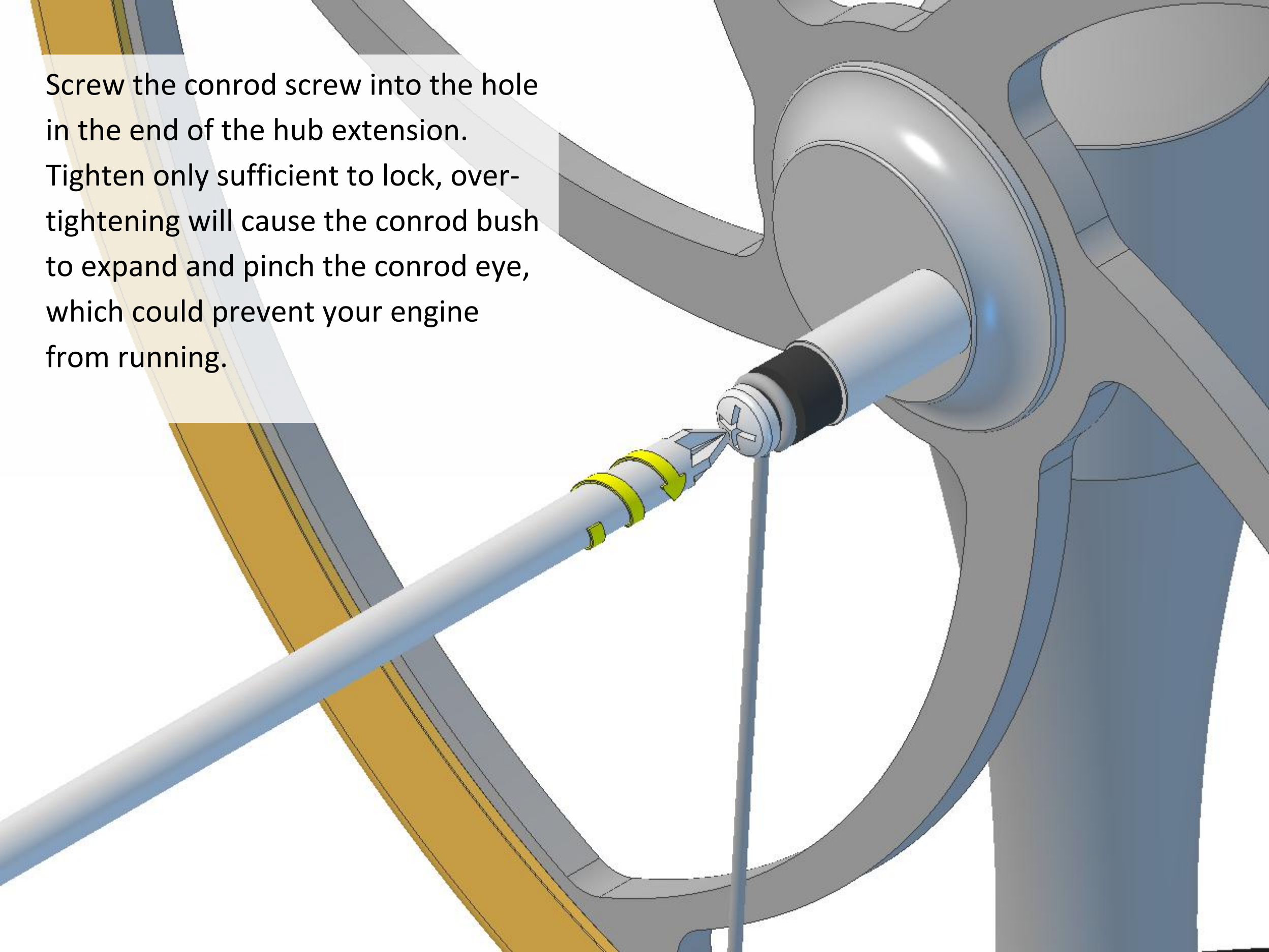

Your engine is now fully assembled.

Check that the flywheel rotates fully, a small amount of resistance will be felt on rotation due to the air pressure inside the main chamber.

Your engine is now ready for operation.

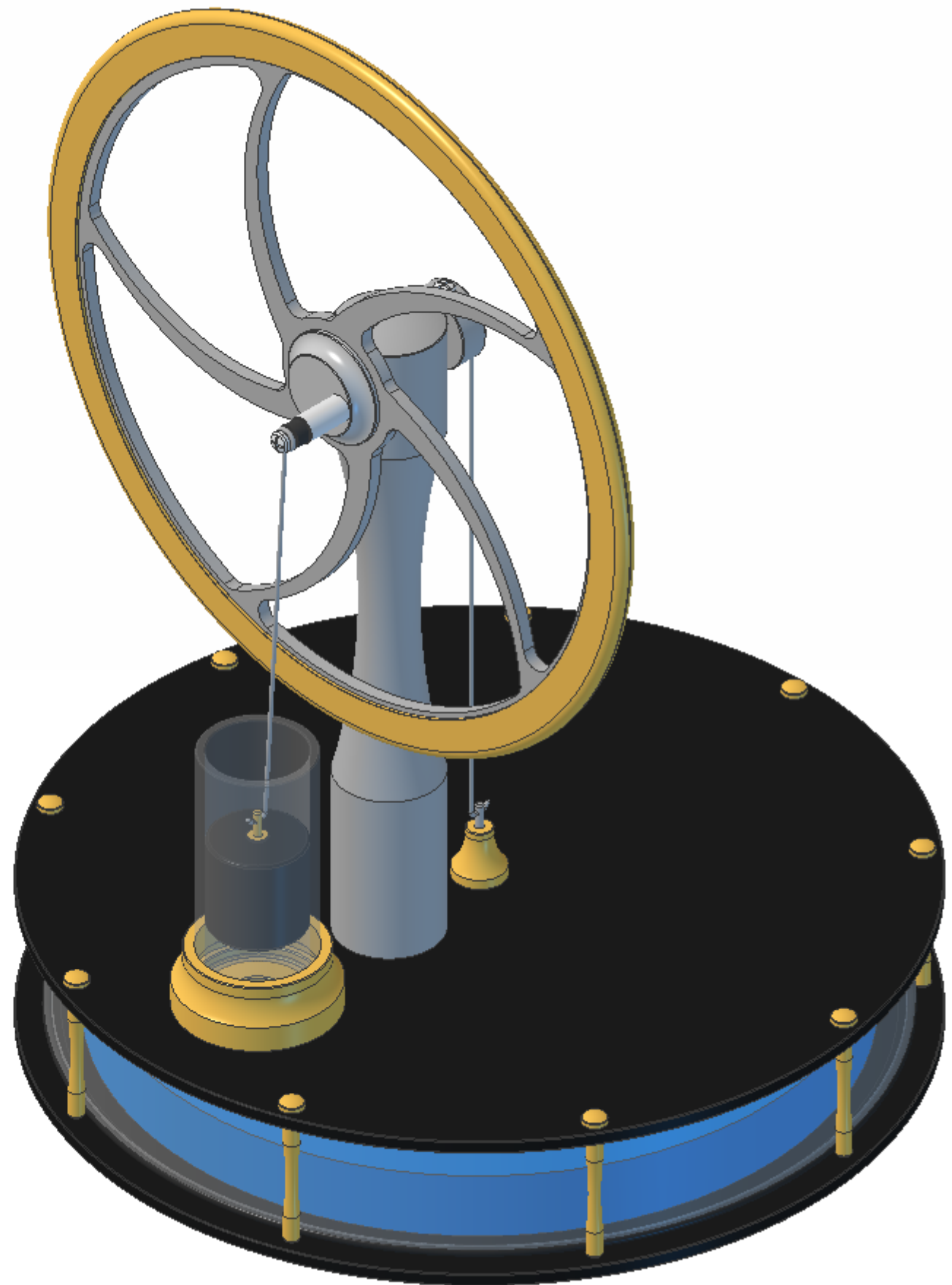

The engine is not self-starting; you will need to give the flywheel a little spin to get it going. After the engine has been on your heat source for half a minute to a minute gently spin the wheel and it should carry on running.

The engine has been designed to run on hand heat, but will run equally as well from a wide variety of heat sources, including Digital TV box, adsl modem, table lamp, hot water - tea or coffee, warm sunlight.

The engine will operate in reverse if you place it on a bowl of ice, this is because Stirling engines operate on a temperature difference, and it doesn't matter if the top plate is cool, as in conventional running, or the bottom plate is cool, as in ice running.

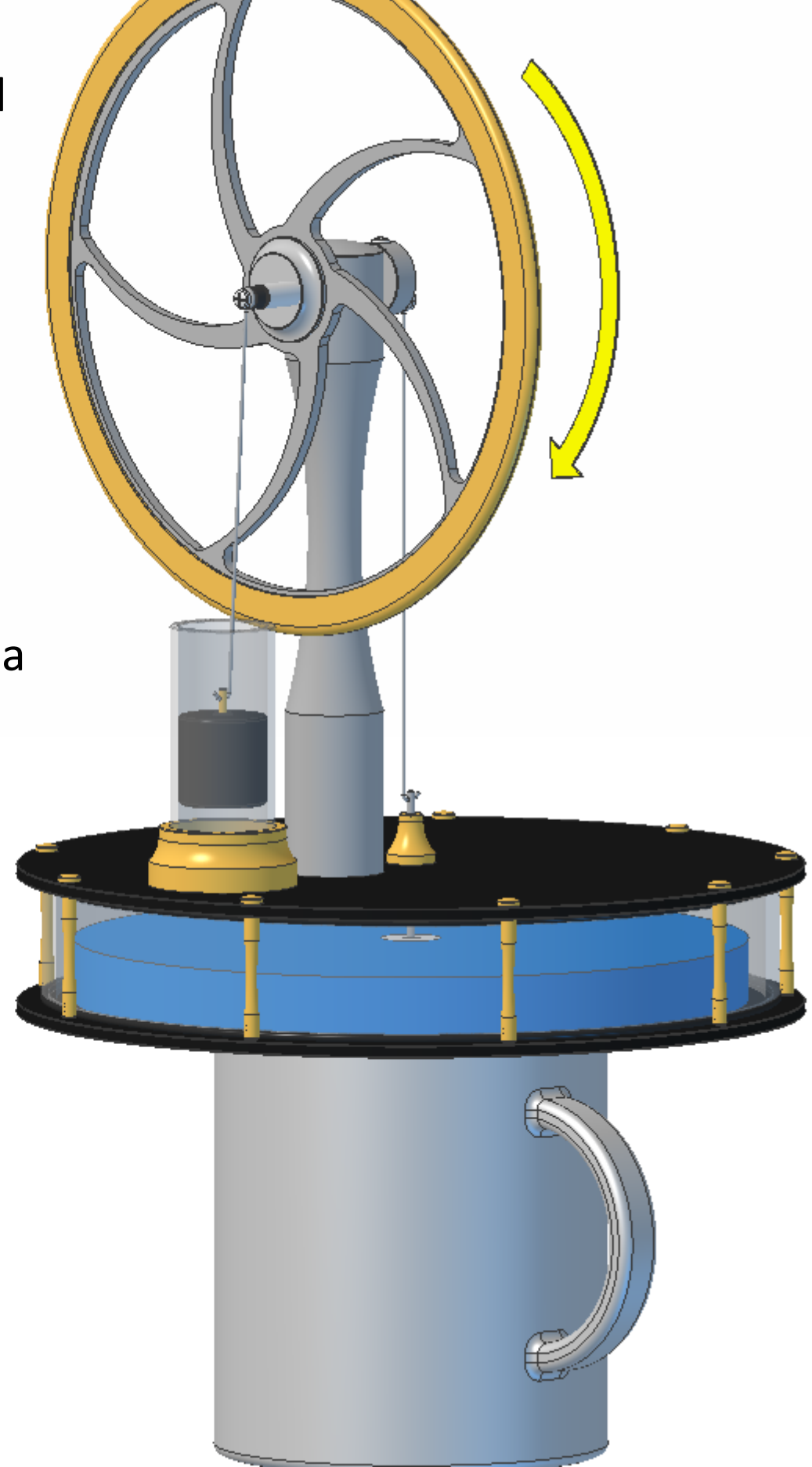

The engine only requires a very small temperature difference between the top and bottom plates to operate, anything hotter than hot water WILL damage it. DO NOT place it on any high temperature heat source (cooker, wood burning stove, candle etc.). This will melt a number of parts on the engine.

If you wish to operate your engine on hot coffee or tea you must allow the liquid to cool for a couple of minutes first.

The hottest heat source that you should use for your KS160 engine must not be hotter than 75°C (167°F).

